

- Ⓓ Anschluss **ausschließlich** durch ausgebildete Elektro-Fachkräfte.
- ⒼB Electrical connection is to be made by trained electrical specialists **only**.
- Ⓕ Le branchement doit **uniquement** être effectué par des professionnels.
- Ⓘ Il collegamento deve essere eseguito **solo** da elettricisti specializzati.
- Ⓔ La conexión **sólo** debe ser realizada por electricistas debidamente formados.
- Ⓗ A ligação deve ser feita **exclusivamente** por profissional eléctrico especializado.
- ⒹL De aansluiting mag **enkel** gebeuren door erkende vakmensen.
- ⒸZ Připojení smí **provádět** pouze kvalifikovaný personál.
- ⒽL Podłączenie **wyłącznie** przez specjalistów-elektryków.
- ⒻI Liittäminen kuuluu **ainoastaan** koulutettujen sähköalan ammattilaisten tehtäviin.
- ⒹUS Подключение проводится только специалистом-электриком.
- ⒽR Bağlantı **sadece** eğitimli elektrik teknisyenleri tarafından yapılmalıdır.
- ⒸN 布线需由专业电工执行

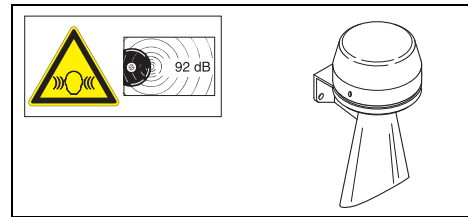

E2621/6	12 V~, 150 mA
E2621/7	24 V~, 70 mA
E2622/1	6-8V~, 400 mA
E2622/2	12 V~, 330 mA
E2622/3	24 V~, 190 mA
E2622/5	230 V~, 15 mA

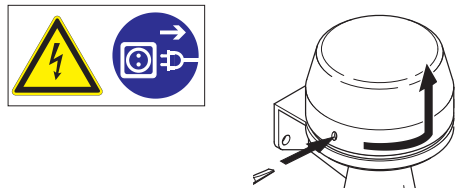
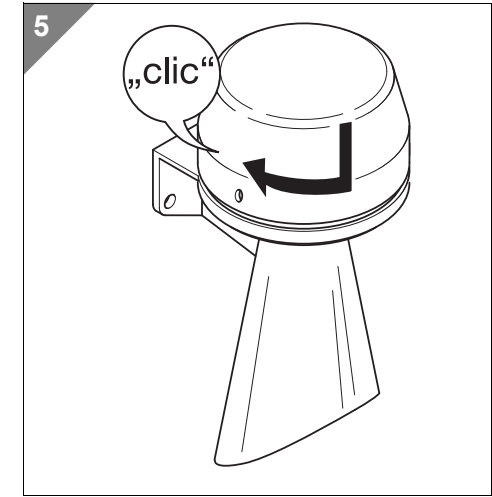
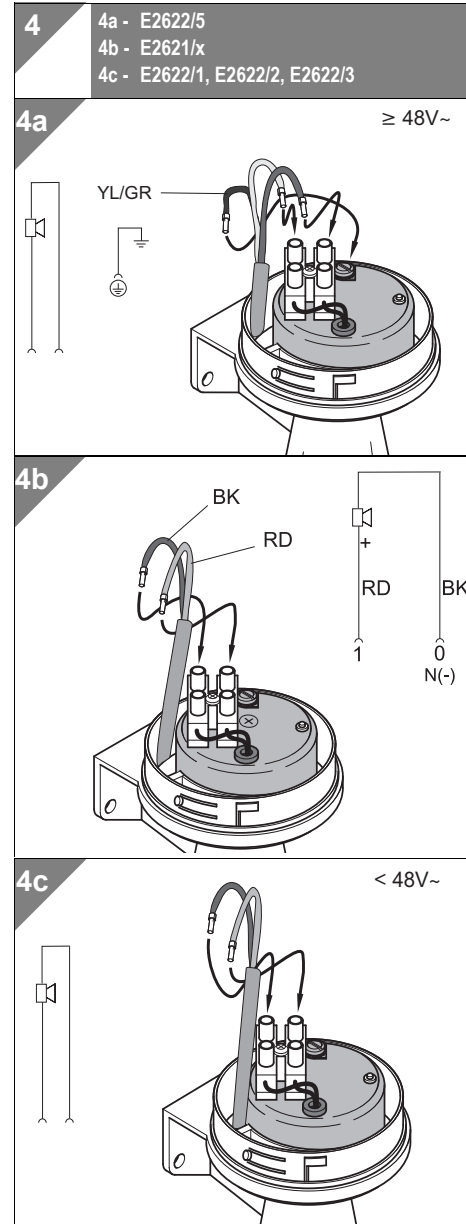
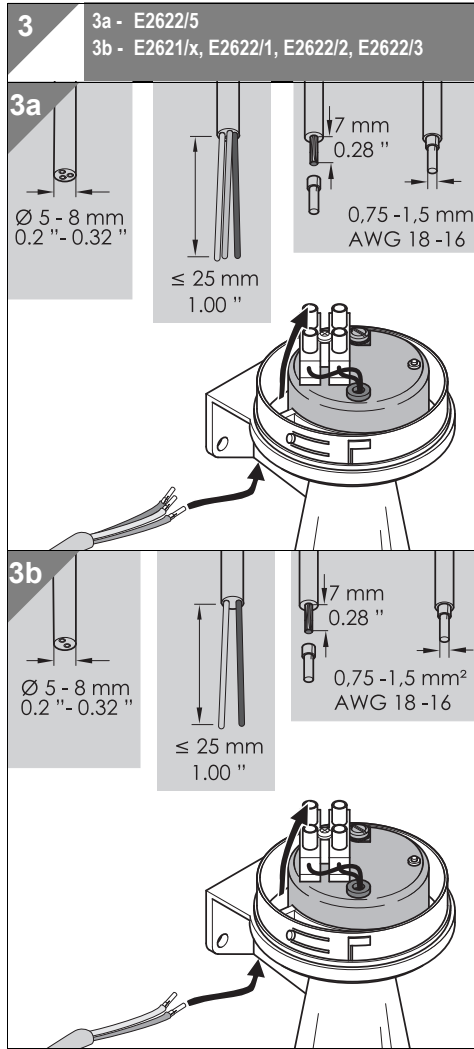
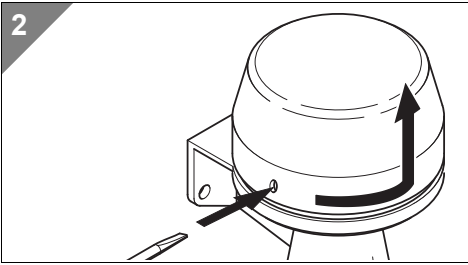
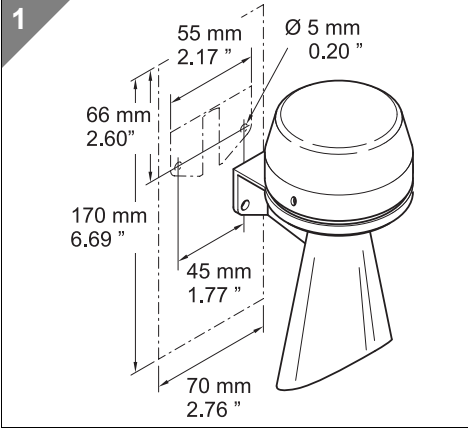

310.482.003.1211

© D

Friedland 
by Honeywell